



Volvo Construction Equipment

L28F

VOLVO COMPACT WHEEL LOADERS 5.4t 49hp



SERVICEABILITY

SAFETY

PERFORMANCE



The Volvo L28F has been made for rental and key account customers, providing the ultimate performance and increased safety at the right price.

The machine you need.

For an optimized performance, the L28F is the perfect solution in order to lower your costs but increase your uptime. With the ideal payload, improved maneuverability for tough job sites and excellent versatility by being able to switch attachments easily, this machine delivers a star performance.

Ideal payload

The L28F boasts an ideal payload capacity (fork payload 2,200 kg) and can be fitted with a one cubic meter standard bucket, providing the ideal wheel loader configuration for all job sites. The machine features large tyres for good maneuverability but its compact design allows it to work in smaller spaces. The L28F's Volvo Powertrain well-matched components also allow for different kinds of buckets – ideal for key account and rental customers.

Compact design

The L28F's compact design means it can work anywhere – especially in tight areas at your jobsite. The machine's height of 2500 mm with standard tires, provides easy access to confined working spaces, such as city centers or urban areas. The transversally mounted engine helps make the L28F as compact as possible - with a short turning radius and excellent manoeuvrability.



Maneuverability

The articulating oscillating joint provides good maneuverability, stability and maintains 100% ground contact in rough terrain, providing operator comfort and superior steering capability. Combined with the machine's powertrain and 100% differential locks front and rear, the L28F boasts superior agility and stability, while increasing operator comfort when operating on uneven terrain.

Plug'n'play compact loader

From forks and buckets to material handling arms, Volvo offers a wide range of attachments to make the machine even more comprehensive and flexible. Volvo attachments, including previous models, are perfectly matched to the machine's linkage, hydraulics and driveline for superior productivity and compatibility. The Attachment bracket is recognized as industry standard.

Safety first.

Safety is at the forefront of all construction activities and Volvo Construction Equipment is dedicated to this core value. The L28F compact wheel loader has been created with safety in mind. The machine's additional internal mirror, bright orange seatbelt and driveline-shutoff via parking brake and seat belt – if the belt isn't plugged in or if the parking brake is engaged then the powertrain won't start – contribute towards a machine created to keep the operator and others safe on your jobsite.



Visibility

The L28F has increased visibility for added safety around your job site. The operator has a more comprehensive view of what's around them with the additional rearview mirror and the cab features a large glazed surface area on all four sides of the machine with an increased view of the attachments for faster, safer work.

More work. Less service.

To avoid a constant stop and service battle, the L28F has long service interval hours and grouped greasing points accessible from the ground for quick and easy scheduled services or maintenance. Built using the best-in-class components for increased machine longevity and great value for money.



Long service intervals

Let your machine work away and be trouble-free by keeping service to a minimum as greasing intervals are every 50-100 hours and engine oil change intervals are every 500 hours. The L28F also offers easy ground level access to service points, including fuel, air, hydraulic and oil filters, radiator, oil dipstick, hydraulic oil level gauges and battery. The long service intervals give you peace of mind, maximum uptime, increases your machine's longevity and lets you control costs.



Best-in-class components

Designed, made and tested in Germany, the L28F is engineered with quality in mind, using best-in-class and main components from renowned suppliers. The machine's components enhance its overall quality because Volvo use the best, robust components rather than less expensive parts that would also do the job such as the disc brake system featured on the L28F.

One machine. Many talents.



The machine you need

Made for rental and key account customers, the L28F compact wheel loader offers top performance and increased safety at the right price.

The ideal payload

The L28F boasts an ideal payload capacity and can be fitted with a one cubic meter standard bucket, providing the ideal wheel loader configuration for all job sites.

Manoeuvrability

The articulating oscillating joint combined with the machine's powertrain and 100% differential locks front and rear provides superior agility and stability.

Compact design

The L28F's compact design means it can work anywhere: The machine's height of 2500 mm with standard tires provides easy access to confined working spaces.

Plug'n'play compact loader

From forks and buckets to material handling arms, Volvo offers a wide range of attachments to make the machine even more comprehensive and flexible.





Safety

The L28F compact wheel loader has been created with safety in mind to keep the operator and others safe on your jobsite.

Visibility

The operator has a more comprehensive view of what's around them with the additional rearview mirror and thanks to the large glazed surface area on all four sides of the cab.



Serviceability

To avoid service battle, greasing points are grouped and accessible from the ground for quick and easy scheduled services or maintenance.



Best-in-class and main components

Designed, made and tested in Germany, the L28F is engineered with quality in mind using best-in-class from renowned suppliers.

Long service intervals

With greasing intervals every 50-100 hours and engine oil change intervals every 500 hours, the L28F give you peace of mind and lets you control costs.

Volvo L28F in detail.

Engine

Volvo D3.1A compliant with Tier III / Stage 3A environmental regulations.
Powerful oil/air cooled, 4 in-line cylinders, 4 strokes, direct injection diesel engine.
Two-stage air filtration: primary paper filter with indicator in cab and safety filter.
Self-bleeding fuel system, independent water separator and fuel filter.

Engine	D3.1A	
Max power at	r/s (r/min)	38.3 (2 300)
SAE J1995 gross	kW / hp	36.4 / 49.5
SAE J1349, DIN ISO 1585 net	kW / hp	36 / 49
Max torque at	r/s (r/min)	28.3 (1 700)
SAE J1349, DIN ISO 1585 net	Nm	178.6
Displacement	l	3.1
Bore	mm	94
Stroke	mm	112

Electrical system

Voltage	V	12
Battery capacity	Ah	100
Alternator rating	W/A	1 120/80
Starter motor output	kW / hp	2.6 / 3.5

Hydraulic system

Open center system with a dedicated gear pump and a double acting, three spools control valve for the working hydraulics.
Standard 3rd hydraulic circuit.
Suction and return lines are filtered through a single 10 µm filter.
The cartridge can be replaced without emptying the hydraulic oil tank.
Integrated cooling system and thermostatically controlled hydraulic oil.

3rd hydraulic circuit maximum flow	l/min	55
at engine speed	r/s (r/min)	38.3 (2 300)
Relief valve pressure	Mpa	23

Linkage

Z-bar linkage offering high breakout force, fast cycle times, and excellent parallel movement with forks.
Lift cylinders / Tilt cylinders 2/1
Lift time (loaded) s 6.0
Lowering time (empty) s 4.0
Dump time s 1.5
Crowd time s 1.5

Steering

Central articulating-oscillating joint.
Independent gear pump for steering circuit.
Hydrostatic steering system.
Angle of articulation ° ±38
Steering pump maximum flow l/min 25
at engine speed r/s (r/min) 38.3 (2 300)
Relief valve pressure Mpa 18.5

Drivetrain

All-wheel drive by two rigid heavy duty planetary axles.
Hydrostatic transmission with direct driven pump.
Hydraulically actuated 100% differential locks in both axles.
Full shift under load from low to high speed range.
Forward - Neutral - Reverse, speed range 1/2 and differential lock buttons on the multifunction joystick.
Inch/brake pedal for variable machine speed control and power transfer to working hydraulics.
Oscillation at wheel, max. mm 245
Track mm 1 422
Angle of oscillation ° ±10

Brake system

Reliable dual service brake, acting upon all four wheels:
1. Wear-free, hydrostatic inching brake
2. Central disc brake, actuated via "inch/brake pedal".
First stage of pedal application actuates the inching facility, the last third of pedal application applies the central disc brake.
Independent mechanically operated parking brake activates a central disc brake, acting upon all four wheels.

Tyre

Size	405/70R18	335/80 R20
Rim	13 x 18	11 x 20

Service / Filling capacities

Engine	l	10.5
Fuel tank	l	60.0
Front axle	l	5.2
Rear axle, incl. Drop-box	l	5.9
Hydraulic tank, incl. hydraulic system	l	60.0

Cab

Instrumentation: All important information are located in the operator's field of vision.
Front display includes following control lights and indicators: differential lock, hydraulic oil filter, hydraulic oil temperature, battery charge, air filter, engine oil pressure, engine oil temperature, handbrake, preheating, forward/reverse direction, machine speed, fuel gauge, hour meter.

Sound Level

Sound level in cab according to ISO 6396 (LpA)	dB(A)	75*
External sound level according to ISO 6395 and EU noise directive 2000/14/EC (LwA)	dB(A)	99*

*NOTE: Uncertainties in given noise values (e.g. uncertainty in production and measuring instruments) are calculated in accordance with ISO 6395: 2008 for the sound power level around the machine and ISO 6396: 2008 for the sound pressure level at the operator position.

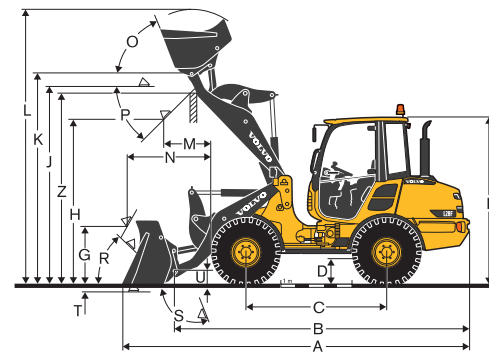

B	mm	4 451
C	mm	2 125
D	mm	335
F	mm	2 520
G	mm	870
J	mm	2 995
K	mm	3 195
O	°	70
P	°	45
R	°	50
S	°	96
U	mm	200
X	mm	1 422
Y	mm	1 744
Z	mm	2 905
a ₃	mm	2 192
a ₂	mm	4 072
a ₄	°	±38

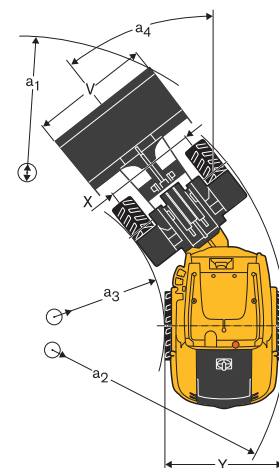

	GENERAL PURPOSE	LIGHT MATERIAL	4-in-1
Capacity heaped	m ³ 1	1.3	0.9
Material density	kg/m ³ 1 800	1 300	1 800
Static tipping load, straight (ISO / DIS)	kg 3 950	3 750	3 700
Static tipping load, full turn 38° (ISO / DIS)	kg 3 600	3 400	3 330
Hydraulic lifting capacity, max.	kN 55	51	50
Breakout force	kN 55	48	54
A Total length	mm 5 250	5 455	5 350
L Lift height, max.	mm 4 160	4 290	4 115
V Bucket width	mm 1 900	1 900	1 900
a ₁ Clearance circle	mm 8 740	8 865	8 910
T Digging depth	mm 75	75	75
H Dump height	mm 2 520	2 355	2 410
M Reach at max. height	mm 720	850	750
N Reach, max.	mm 1 500	1 630	1 530
Operating weight	kg 5 400	5 450	5 600

Loading Fork

Center of gravity 500 mm		
Tipping load, full turn (ISO / DIS)	kg	2 750
Payload load acc. to EN 474-3, 60/80 %	kg	1 650 / 2 200
Payload load 80%, transport position, 38° deg. and full turn	kg	2 500

Equipment.

STANDARD EQUIPMENT

Engine

Diesel engine, direct fuel injection
 Extra fuel filter
 Cold start aid
 Dry-type air filter

Electrical system

Alternator 80 A
 Starter motor 2.6 kW

Lighting

Main head lights (halogen) upper/dipped/asymmetrical
 Working light (rear right)
 Parking lights
 Rear lights
 Brake lights
 Direction indicators
 Hazard warning lights
 Cab lighting

Instrumentation & controls

Multi-function lever
 12 Volt accessories socket
 Forward horn
 Hazard warning switch
 Safety start
 Analogue information for:
 Fuel level
 Operating hours
 Illuminated symbols for:
 Differential locks
 Battery charging
 Indicators (left/right)
 Main beam head lamp
 Pre-heater (option)
 Direction (forward/reverse)
 Travel (quick, slow)
 Fuel level
 Illuminated symbols with acoustic signal (with ignition on) for:
 Engine temperature
 Engine oil pressure
 Hydraulic oil temperature
 Hydraulic oil filter
 Air filter restriction
 Parking brake

Drivetrain

Hydrostatic drive
 Operator-selected 100% differential locks in both axles

Cab Exterior

ROPS/FOPS-cab with flexible mountings
 Lockable door
 All-round tinted safety glass
 Windscreen wiper (front/rear)
 Windscreen washer (front/rear)
 Openable window on the right side
 Door stops
 External rear view mirrors (right/left)

Cab Interior

4-way adjustable operator's seat
 Seat belt
 Sunvisor
 Heater with air-filter and defroster (front/rear)
 Cab ventilation
 Storage box in cab

STANDARD EQUIPMENT

Hydraulic system

Gear-type pump
 Control valve three-spool system
 3rd hydraulic circuit

Working Equipment

Bucket level indicator
 Hydraulic attachment bracket (same as ZL602,L25 Z, L30)

Carriage Body

Fenders (front/rear)
 Lockable engine hood
 Vertical exhaust
 Towing device
 Lifting eyes
 Tying down eyes

International Standards for Machines and Production

Quality: DIN/ISO 9001
 Safety: conform to CE regulations
 Machine guide-lines 2006/42/EC
 ROPS ISO 3471
 FOPS ISO 3449
 Operating weight: ISO 7131
 Tipping load / Payload: ISO 14397-1
 EMC (Electromagnetic Compatibility)
 89/336/EEC plus supplement
 Environment: DIN/ISO 14001
 Sound regulation: 2000/14/EC

OPTIONAL EQUIPMENT (Standard on certain markets)

Engine equipment

Pre-heater
 Pre cleaner air filter (Turbo II)
 Oilbath air filter

Cab

Handthrottle
 Hand control inch valve
 Airconditioner
 Radio
 Adjustable steering column
 Working lights (2 front/1 rear left)
 Air suspension operator's seat

Working Equipment

Boom suspension system

Hydraulic system

Hydraulic couplings for:
 3rd hydraulic circuit
 Single lever with integrated 3rd function

Environment

Biodegradable hydraulic oils

Safety

Rotating beacon
 Audible reverse alarm
 Anti-theft system
 Protective guards for:
 Main head lights
 Working lights
 Rear lights

Service and maintenance

Tool kit

VOLVO

Volvo Construction Equipment

www.volvoce.com