



Volvo Construction Equipment

SD135B

Volvo Single Drum Compactors 12.6-13.3 t 110 kW



A passion for performance

At Volvo Construction Equipment, we're not just coming along for the ride. Developing products and services that raise productivity – we are confident we can lower costs and increase profits for industry experts. Part of the Volvo Group, we are passionate about innovative solutions to help you work smarter – not harder.

Helping you to do more

Doing more with less is a trademark of Volvo Construction Equipment. High productivity has long been married to low energy consumption, ease of use and durability. When it comes to lowering life-cycle costs, Volvo is in a class of its own.

Designed to fit your needs

There is a lot riding on creating solutions that are suited to the particular needs of different industry applications. Innovation often involves high technology – but it doesn't always have to. Some of our best ideas have been simple, based on a clear and deep understanding of our customers' working lives.



You learn a lot in 180 years

Over the years, Volvo has advanced solutions that have revolutionized the use of construction equipment. No other name speaks Safety louder than Volvo. Protecting operators, those around them and minimizing our environmental impact are traditional values that continue to shape our product design philosophy.

We're on your side

We back the Volvo brand with the best people. Volvo is truly a global enterprise, one that is on standby to support customers quickly and efficiently – wherever they are.

We have a passion for performance.



Volvo Trucks



Renault Trucks



Mack Trucks



UD Trucks



Volvo Buses



Volvo Construction Equipment



Volvo Penta



Volvo Financial Services

Versatile performance

Volvo B-series soil compactors are packed with advanced technology. The drum is configured with ease while the engine controls itself. The compactors adapt to your application and jobsite to provide maximum versatility and performance.

Frequency and amplitude choices

Easily adjust the vibration frequency from the operator console to compensate for changing soil types and conditions. Two frequency settings are standard and for even greater versatility, five frequency options are available. High and low amplitudes can also be selected.

Adaptive power

Adaptive power tailors machine performance by adjusting engine and hydraulic systems to individual job site requirements, providing the exact amount of power needed for increased efficiency. It's designed to run the machine at the optimal level needed for the job.



Application versatility

The machine can be set up in three different configurations and is available with smooth or padfoot drum. The compactor is quickly and easily converted from a smooth drum by clamping on a padfoot shell. The padfoot shell kit allows the machine to work in different applications and increases versatility.

Gradeability

The Volvo traction system provides excellent climbing and traction capabilities in difficult applications, such as steep inclines or slippery surfaces. The system prevents wheel or drum spin, improving gradeability, performance and productivity.





DRUM PERFORMANCE

Volvo's advanced drum control system delivers multiple frequencies, dual amplitude, and optimized centrifugal force – matching the drum's performance to your application. The choice of high or low amplitude is easily selected, giving you the flexibility to adjust the drum's dynamic force based on the job and material depth. The auto vibration feature also increases ease of operation and productivity.



VOLVO ENGINE

Volvo's premium Stage IV engine delivers high torque at low rpm for superior performance and low fuel consumption. Designed to lower emissions and increase efficiency without compromising power.

Power up, fuel down

The perfectly optimized Volvo Stage IV engine delivers high torque at low rpm for superior performance and low fuel consumption. The compactor's engine has been developed to offer greater fuel efficiency, increasing uptime and reducing costs.

Efficient cooling system

The hydraulically-driven fan with variable speed draws power only when needed. Lower fan speeds reduce noise, resulting in greater operator comfort and a lower total cost of ownership.



ECO mode

ECO mode is now standard and always on by default. It adjusts the engine speed to match the operation mode and achieves up to a 40% reduction in fuel consumption.

Passive regeneration

The new passive regeneration provides continuous and simplified operation. Volvo's passive regeneration cleans the filters automatically during normal operation without any input from the operator or effect on performance.



Eccentric design

The eccentric design delivers more efficiency while using less power. Matching the required performance to suit your application, the eccentric is designed for faster ramp up speeds at lower pressure for increased fuel efficiency.



Packed with intelligence

COMFORTABLE ENVIRONMENT

The ROPS/FOPS certified cab provides a safe and comfortable working environment with all-around visibility.

ECO mode

ECO mode is now standard and always on by default. It adjusts the engine speed to match the operation mode.

HIGH QUALITY COMPONENTS

The compactor features the highest quality components, clever routing and clean design.

Heavy-duty

The heavy-duty drum, center joint and front frame components are designed and manufactured with durability in mind.

Frequency and amplitude choices

Easily adjust the vibration frequency from the operator console to compensate for changing soil types and conditions.

DRUM PERFORMANCE

Volvo's advanced drum control system delivers multiple frequencies, dual amplitude, and optimized centrifugal force.





VOLVO ENGINE

The perfectly optimized Volvo Stage IV engine delivers high torque at low rpm for superior performance and low fuel consumption.

Passive regeneration

Passive regeneration functions automatically during operation without input from the operator or effect on machine performance.

Service access

The electric engine hood lifts up giving extensive ground level access to the engine compartment.

CareTrack

CareTrack provides you with reports, alarms, location and service hours for better machine management.

Gradeability

The Volvo traction system provides excellent climbing and traction capabilities in difficult applications.

Impact meter

Integrated into the display, the impact meter ensures you travel at the right speed for target compaction.



COMFORTABLE ENVIRONMENT

The ROPS/FOPS certified cab provides a safe and comfortable working environment with an efficient heating and air conditioning system and all-around visibility. With floor to ceiling cab glass, the operator has an excellent forward drum view as well as superior front and rear visibility.

Control in comfort

Step up to the Volvo designed cab and experience industry-leading low noise levels, ultimate comfort and a productive working environment. Safe, spacious and with improved all-around visibility, operators will work efficiently with less fatigue in a Volvo compactor.

Fully adjustable seat

The fully adjustable seat rotates and slides to enhance front and rear visibility for increased safety and comfort.



Climate control system

The cab is equipped with industry-leading climate control to ensure a comfortable environment inside the cab, whether heating or air conditioning is required. High air intake and positive cabin pressure helps to reduce dust from entering the cab.



Operator display

The high-tech color operator display presents operational information and key diagnostics, reducing the need for regular physical checks. Easy to see in direct sunlight, further functions include service interval information and machine operating conditions. The control keypad is conveniently located on the operator's side console and controls are grouped together for comfort and efficiency.



Impact meter

Integrated into the display, the impact meter ensures you travel at the right speed for target compaction. The impact meter measures impacts per meter for a uniform smooth finish.

Robust and reliable

Volvo Construction Equipment produces the most robust and durable compactors on the market. The B-series soil compactors provide easy service access for increased uptime and quick maintenance.

Service access

The cab tilt is standard, providing access to all hydraulic components. For class-leading access, the electric engine hood lifts up giving extensive ground level access to the engine compartment. Maintenance and inspections can be conducted more efficiently with minimal downtime – increasing overall productivity and reliability.



Sealed electronics

All components and electronics have been moved into the cab and mounted on the rear wall, protecting them from the elements. Fuses are accessible behind the fuse panel for improved accessibility.

CareTrack

CareTrack is the state-of-the-art telematics system designed for Volvo Construction Equipment. Stay informed, receive reports, alarms and information such as fuel status, machine location and hours so you can plan your service more efficiently. Stay ahead of unscheduled downtime and check that your machine is being operated efficiently.



Heavy-duty

The heavy-duty drum, centre joint and front frame components are designed and manufactured with durability in mind. The thick steel drum shell is engineered for longevity and performance. Frames are robotically welded and built from high quality steel with precise and consistent welds guaranteeing a strong structure.





HIGH QUALITY COMPONENTS

The compactor features the highest quality components, clever routing and clean design. The engine, hydraulics and electronic components work in harmony to deliver superior performance and increase machine life.

Specifications

Model		SD135B	
Drum type		Smooth	Padfoot
Machine Weights (inc. cab and inside scraper)			
Operating Weight (CECE)	kg	12 600	13 300
Static Weight @ Drum	kg	7 150	7 850
Static Weight @ Tyres	kg	5 450	5 450
Shipping Weight	kg	12 470	13 170
Drum			
Width	mm	2 134	2 134
Diameter	mm	1 510	1 510
Shell Thickness	mm	30	30
Diameter Over Pad Feet	mm	-	1 760
Pad Feet	number of	-	112
Pad Height	mm	-	127
Pad Tip Area	cm ²	-	135.3
Vibration			
Frequency	Hz	30.8 / 33.8	30.8 / 33.9
Optional 5 Frequency (High Amp)	Hz	23.3 - 30.8	23.3 - 30.8
Centrifugal Force	High Amp	kN	280
	Low Amp	kN	249
Nominal Amplitude	High Amp	mm	1.87
	Low Amp	mm	1.38
Propulsion			
Type	Hydrostatic		
Tires	23.1-26 R3 8PR TT		23.1-26 R1 8PR TL
Drum Drive	Planetary Gear Box		
Travel Speed			
	High	km/h	0-9.9
	Low	km/h	0-4.2
Engine			
Make / Model	Volvo D4 Stage IV		
Engine Type	Turbocharged 4-cylinder		
Rated Power @ 2 200 r/min	kW	110	
Electrical System			
Voltage (Negative ground)	Volt	24	
Alternator	Ah	80	
Batteries	CCA	2 x 1 000	
Brakes			
Service	Hydrostatic		
Parking / Secondary	Spring-applied, hydraulically released on drum and axle		
Miscellaneous			
Articulation Angle	°	+/- 35	
Oscillation Angle	°	+/- 12	
Fuel Capacity	L	130	
Hydraulic Oil Capacity	L	75	
Gradeability (theoretical)	%	66	46
Guaranteed Sound Level			
Operator's Ear, acc. to ISO 11203:2009	LpA dB(A)	75 (Cab) - 87 (Canopy)	
External, acc. to Directive 2000/14/EC	LwA dB(A)	105	

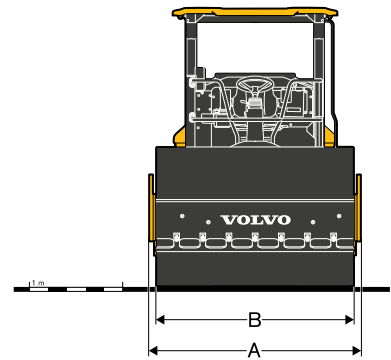
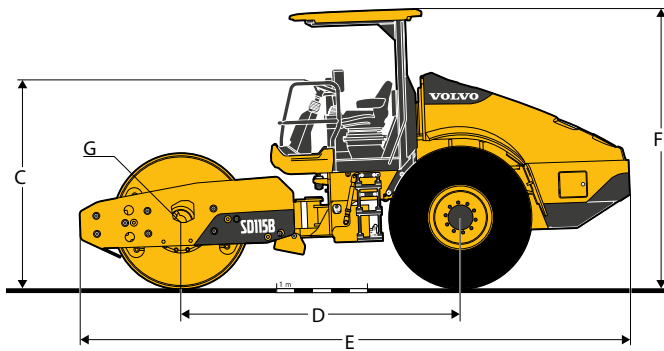

DIMENSIONS

		SD135B	
	Unit	Smooth drum	Padfoot drum
A	mm	2 286	2 286
B	mm	2 134	2 134
C	mm	2 269	2 288
D	mm	3 095	3 095
E	mm	6 091	6 091
F	mm	3 000	3 020
G	mm	755	774

Equipment

SELECTION OF VOLVO OPTIONAL EQUIPMENT

Tires



Padfoot drum



Blade



Work lights



Impact meter



Traction system



Not all products are available in all markets. Under our policy of continuous improvement, we reserve the right to change specifications and design without prior notice. The illustrations do not necessarily show the standard version of the machine.

VOLVO

Volvo Construction Equipment

www.volvoce.com